

# VT16 Application Note

## 1> Application circuit for external joystick(Reference Only)

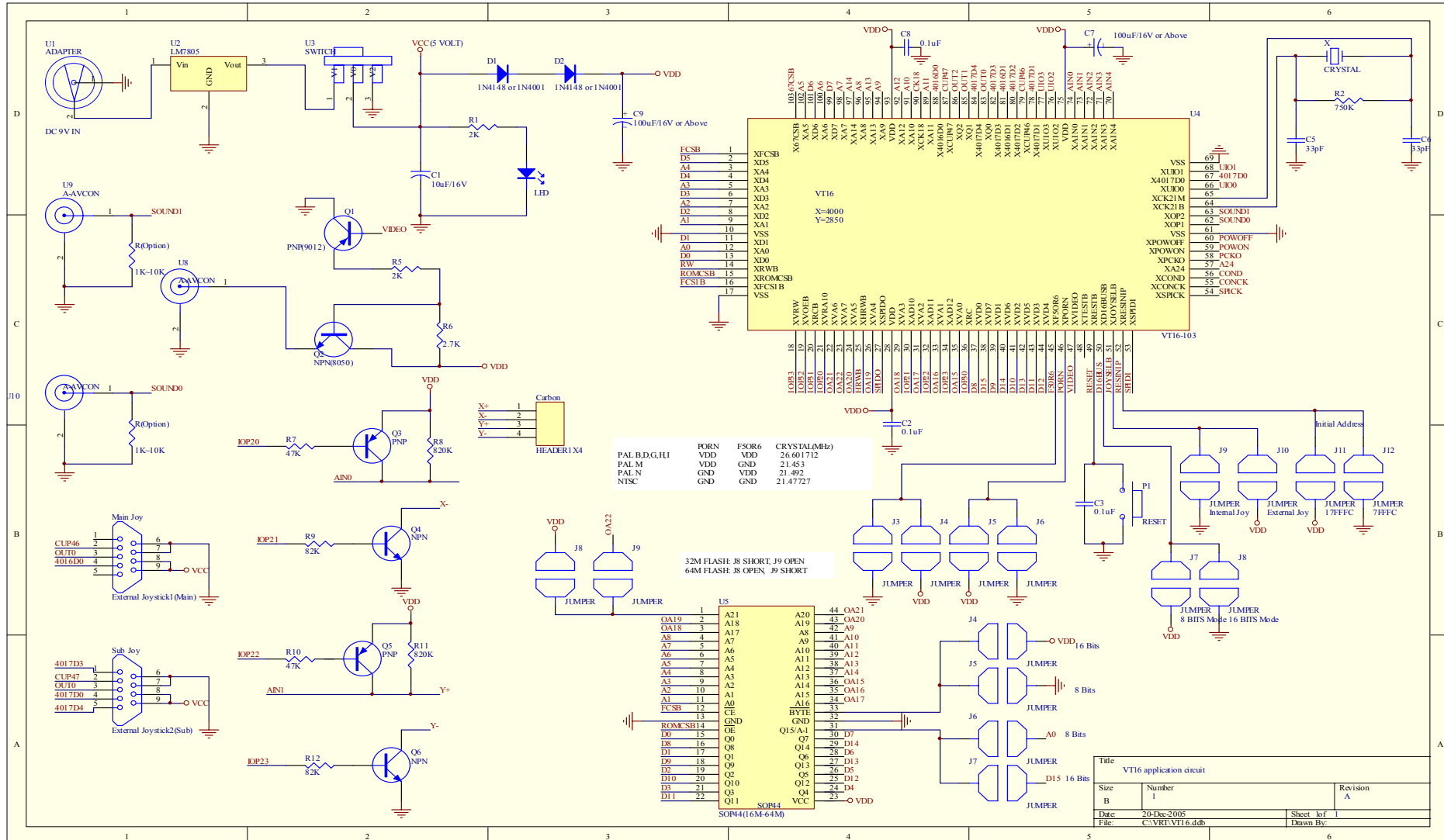

# VT16 Application Note

--- Application circuit for Internal joystick(Reference Only)

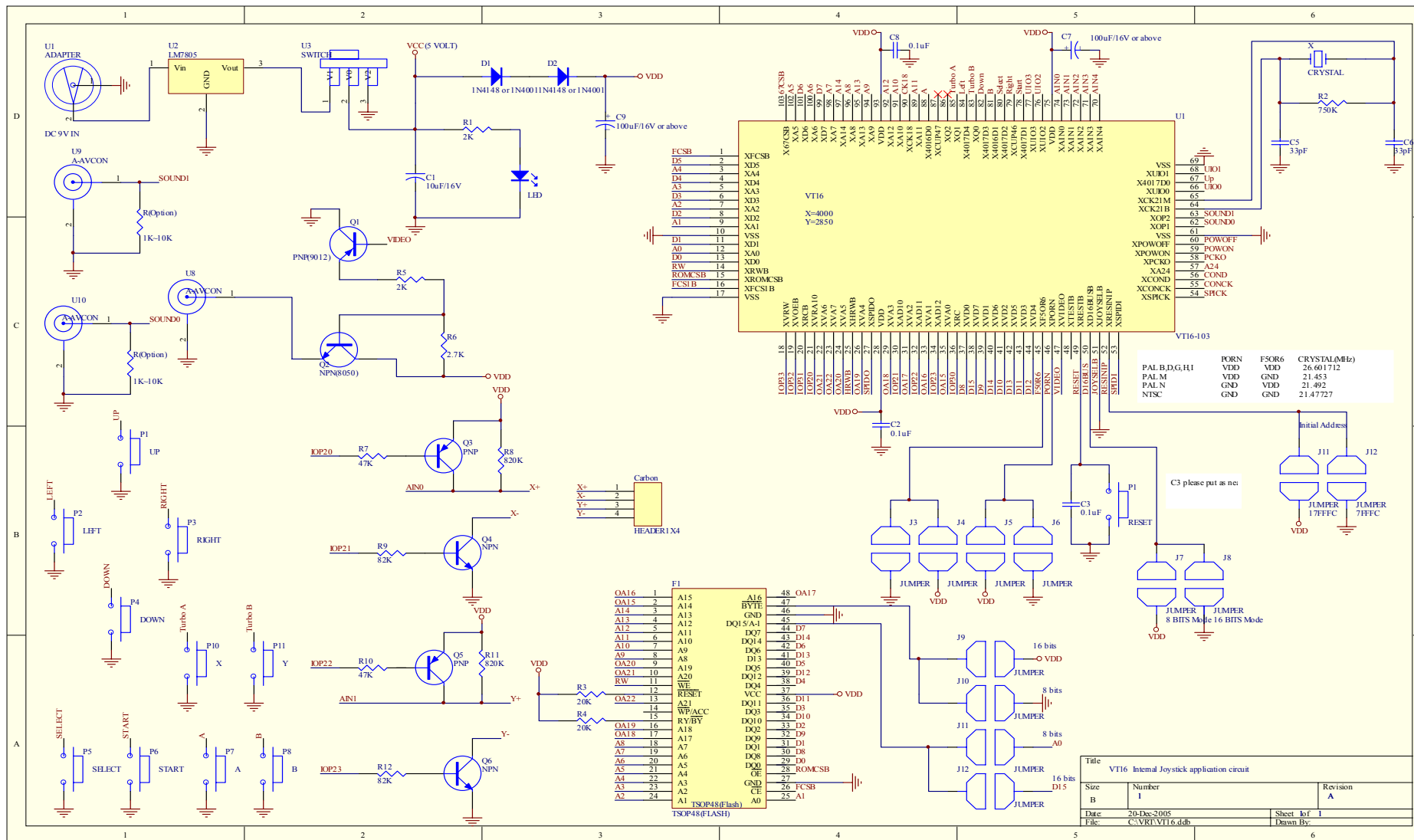

## VT16 Application Note

2>. Power source must the constant voltage and current.

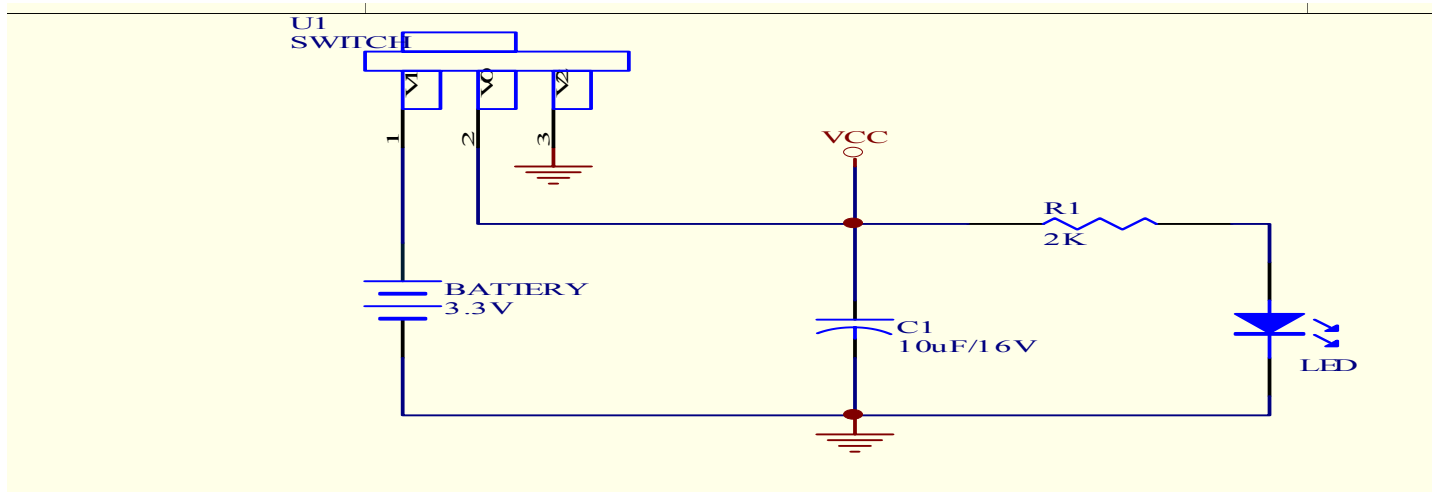
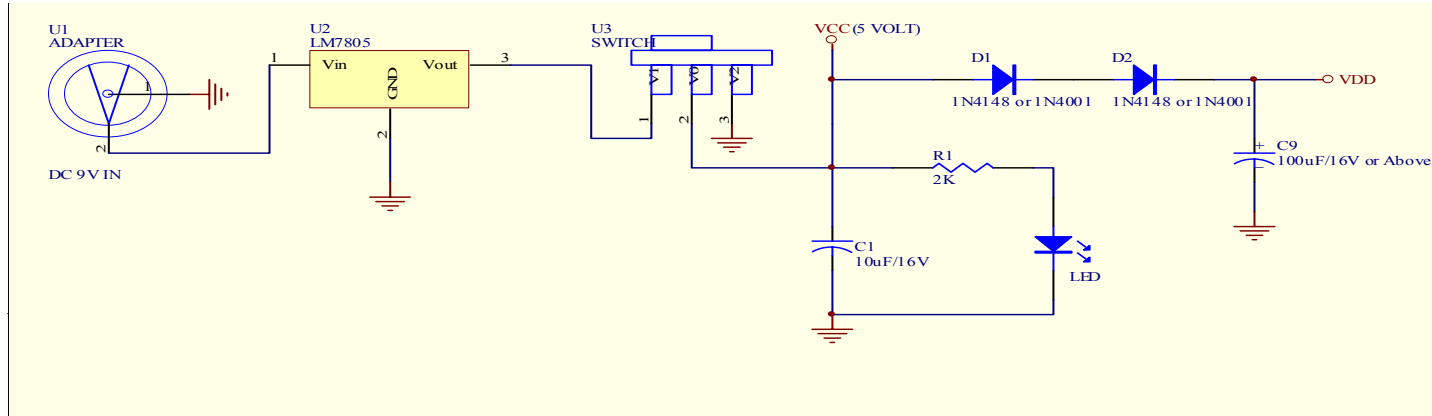

--- Because this IC is 3.3 volt application, if you want to add the extra components (for example cartridge, SRAM, TTL and so on) which operation voltage is not 3.3 volt, please pays attention to the power design of VT16 and the extra components.



## VT16 Application Note

- 3>. Normally, a 0.1uF capacitor is connected between VT16 (VDD) and (VSS) for noise bypassing. The small capacitor should be as close to the pad as possible on PCB layout. At the backside of the chip (Substrate) must be earth. The width of VDD and VSS line on PCB is recommended to be as large as possible.
- 4>. The power path layout on PCB must be noticed to avoid the noise coupling from digital signal and wire cross to different PCB layers. The best solutions are far away from digital signal cross over the power path in bottom side. In some special case, a large capacitor (such as 10uF to upper) is needed for power stability.
- 5>. Normally, a 0.1uF capacitor is connected between VT16 RESET pin and GND, otherwise it will cause of system abnormal issue. The small capacitor should be as close to the pad as possible on PCB layout. The replacement capacitor cannot add too big, otherwise the replacement time quite to be long. The best choice is 0.1uF.
- 6>. The crystal (Xtal) of the outer covering must earth for strengthens the shielding effect. For avoiding disturb, the crystal should be as close to the pad as possible on PCB layout. Please choose the good quality control crystal (Xtal), otherwise when links with TV it will create the frequency not to match and the TV output image color not right issue.
- 7>. PCB design as far as possible considered adds 0.1uF (104) to eliminates the noise.
- 8>.Quality of the welding, must use welding wire above 63/37 (Pb/Sb to compare) and use constant temperature iron and to earth.
- 9>. COB black rubber use matters needing attention:**
- In order to avoid the reliability problem, please use the lower ion content and is not easy to absorb the moisture of black rubber material.
  - For avoids rapidly the solidification has stress of the machinery in the black rubber to create hits the line broken. When heats up the black rubber to solidification please pays attention to the establishment of the temperature decrease the procedure.
  - In view of the reliability requests a higher product to have to choose reliability the higher black rubber material quality.
- 10>. When you use the single bus and 8 bits data mode, also is only uses a memory body (MASK ROM either FLASH or OTP or SRAM... ), please select its access time compared to 70ns the quick chip, otherwise the system does not normal operation. When you use the single bus and 16 bits data mode, also is only uses a memory body (MASK ROM either FLASH or OTP or SRAM... ), please select its access time compared to 120ns the quick chip.**
- 11>. Static electricity protective measure: Static electricity protection working condition as follows:

## VT16 Application Note

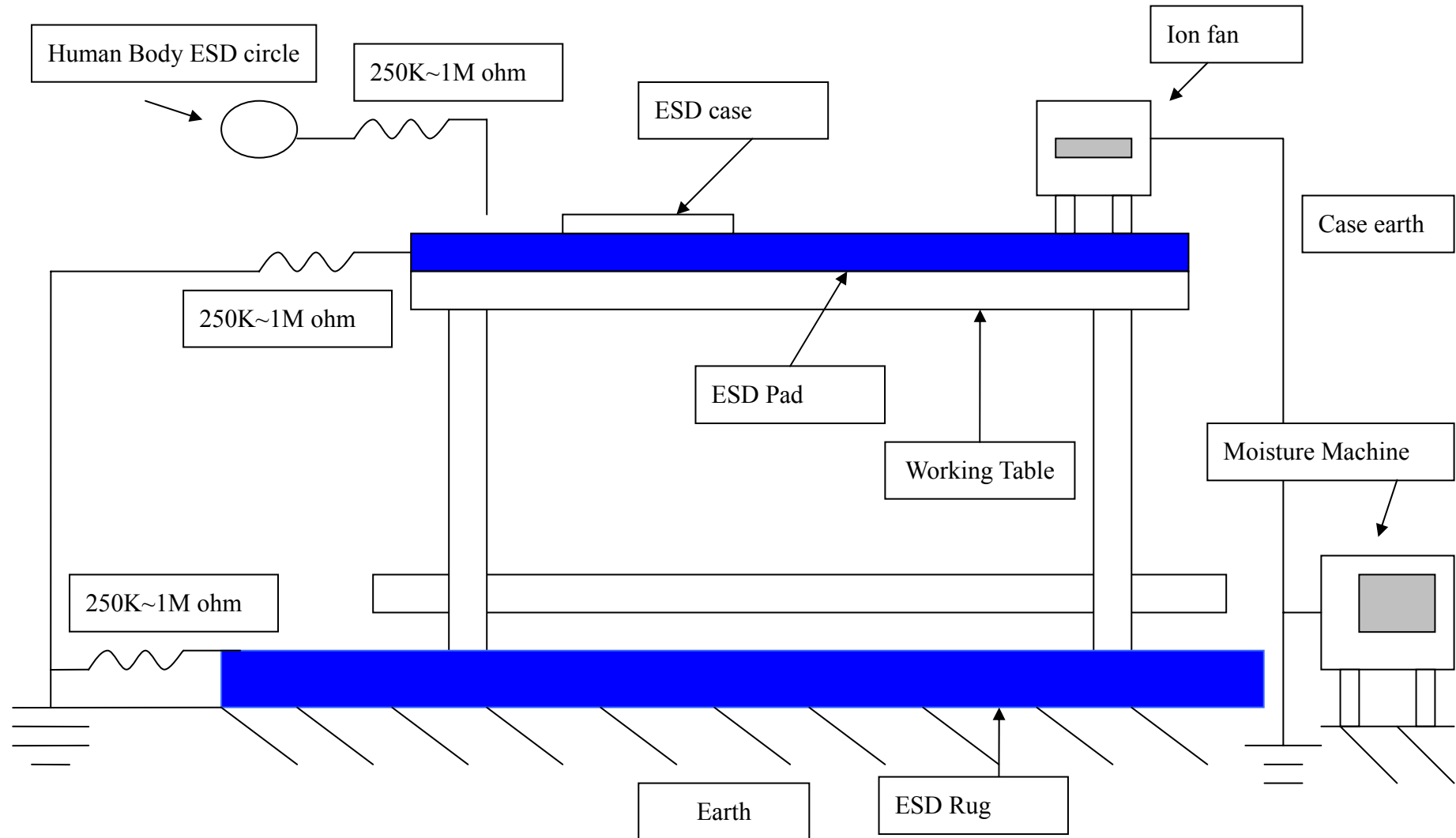

## ***VT16 Application Note***

---When work can contact IC the personnel must wears the static electricity link, the static electricity link itself impedance must. (avoid when 250K ohm~1M ohm as a result of leaking injures human body)

--- Takes IC not with the bare hand, the nylon glove or the rubber glove, but should use cotton material of the anti- static electricity cotton glove.

--- The work clothes should avoid using easy to produce the static electricity fibroin or the wool nature material, should use cotton material of material the anti- static electricity.

--- Relative humidity control: Relative moisture is very big regarding the static electricity production influence, therefore in the feeding area, the assembly area, the test area, the storage area and so on should maintain relative moisture between 40% RH~ 60% RH

--- When transmits IC should put IC on the anti- static electricity bag or in the anti- static electrophorus.

--- When use iron because iron head has some kind of electric potential, therefore may not when treated welds the part still had the ultra-power source welds the product.

--- Instrumentation equipment, like iron, test machine, soldering tin trough, entire foot machine... and so on, should specially pay attention to the cabinet earth, another power source should use three types, avoids by the equipment leakage harming I C .

--- Attracts the tin gun, the high speed of flow gusty area (vent, air gun) is extremely easy to produce the static electricity, also must special attention.

--- Any has the storage or produces material of the electrostatic charge (for example the electric capacity, the voltage buzzer... and so on), to forbids when the material still had the electric charge to contact the IC.

--- In the automated manufacture equipment, the static electricity production possibly comes from the part migration. If transports the leather belt, loses, tray and so on, should the special attention static electricity protection.

--- Nearby low temperature stove because relative moisture obviously drops, also should the special attention static electricity protection

--- The assembly material should select the anti- static electricity material, like module or plastics.

## VT16 Application Note

12>.When PCB design please note the anti-jamming, special pays attention to the audio line and the video output unit. Please arrive to this two output lines from the IC end must lead between output to run two sides which the line passes through to add the grounding to make the barrier, so may reduce noise of the loudspeaker and enhance quality of the image output.

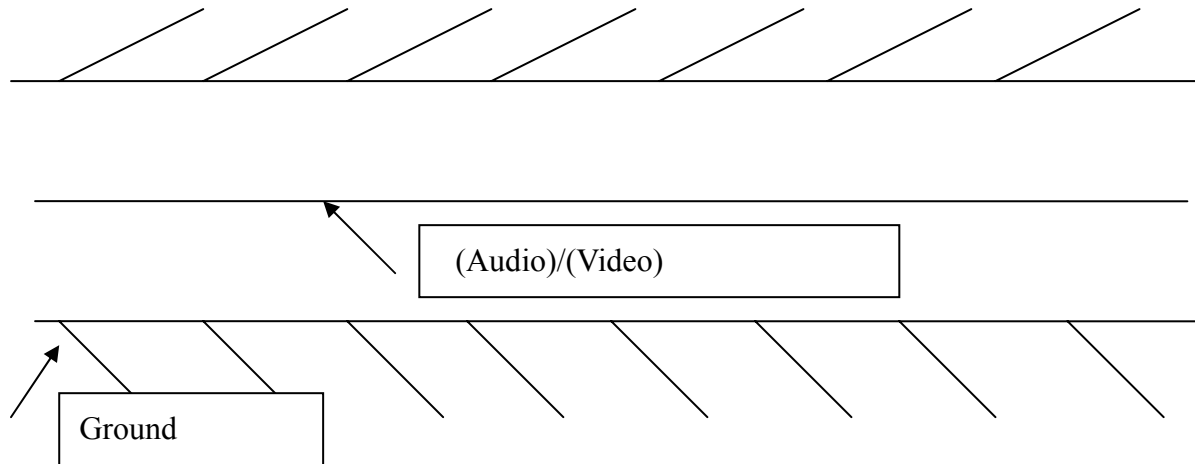

---- In order to avoid the noise issue of power coupling effect, please you consider to add a big capacitor between VT16 Pin75(VDD) and GND. The capacitor can be use 100uF/16V or above(220uF/16V is better), it could be reduced the audio noise. Or you can add this capacitor after 1N4001 or 1N4148.(Like item2 C9)

## VT16 Application Note

### 13>. Image output (Video output)

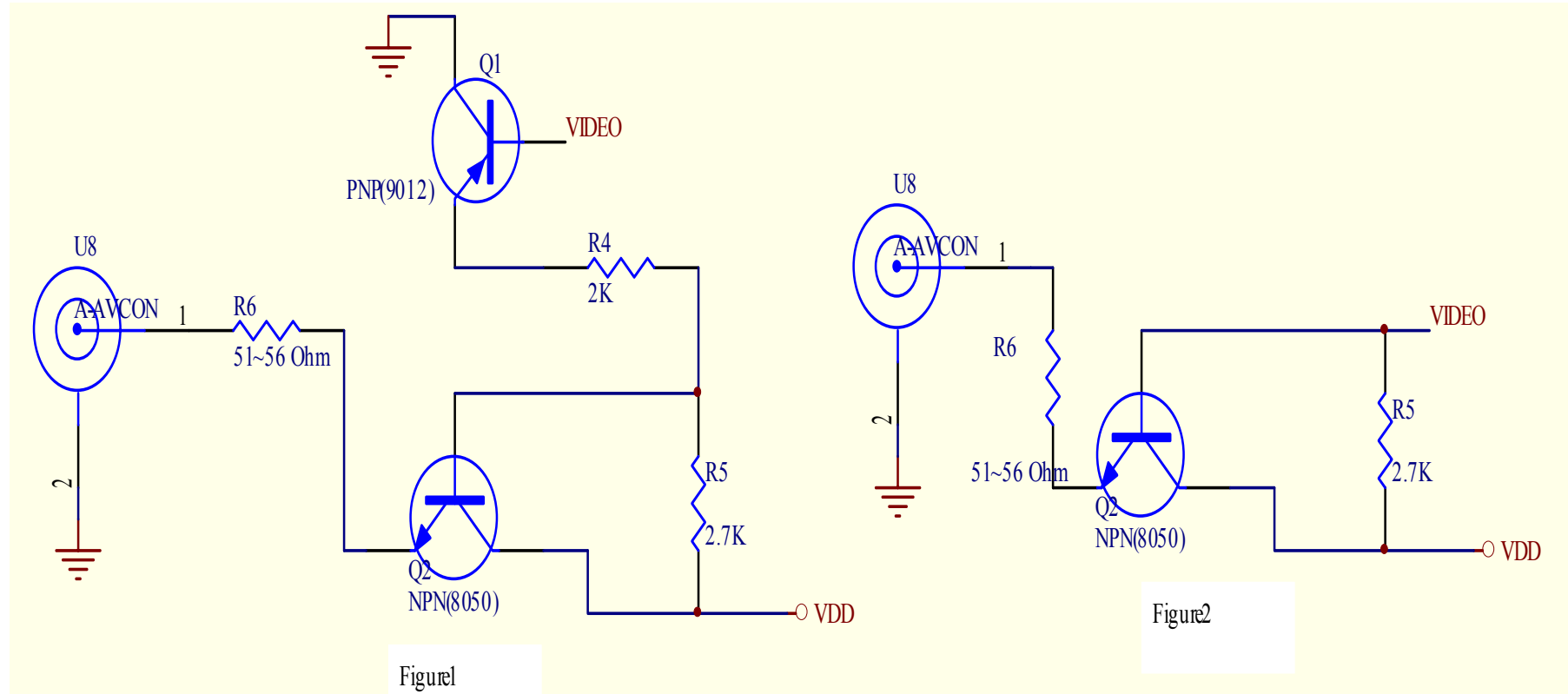

--- Two circuits could be used for Video output. You can select Figure1 or Figure2, the difference is the TV image Bright Darkness.

--- As Figure1 circuits, Bright partial may adjust regarding the TV image output color using R4, R4 resistance number bigger color darker, otherwise then is brighter.

--- As Figure1 circuits, R6 is a resistance which adjust will, you may match R4 to adjust your TV image bright darkness, also may reduce the partial TV video frequency disturbance.

--- As Figure2 circuits, R6 is a resistance which adjust will, also may reduce the partial TV video frequency disturbance.



## VT16 Application Note

14>.Audio output circuit:

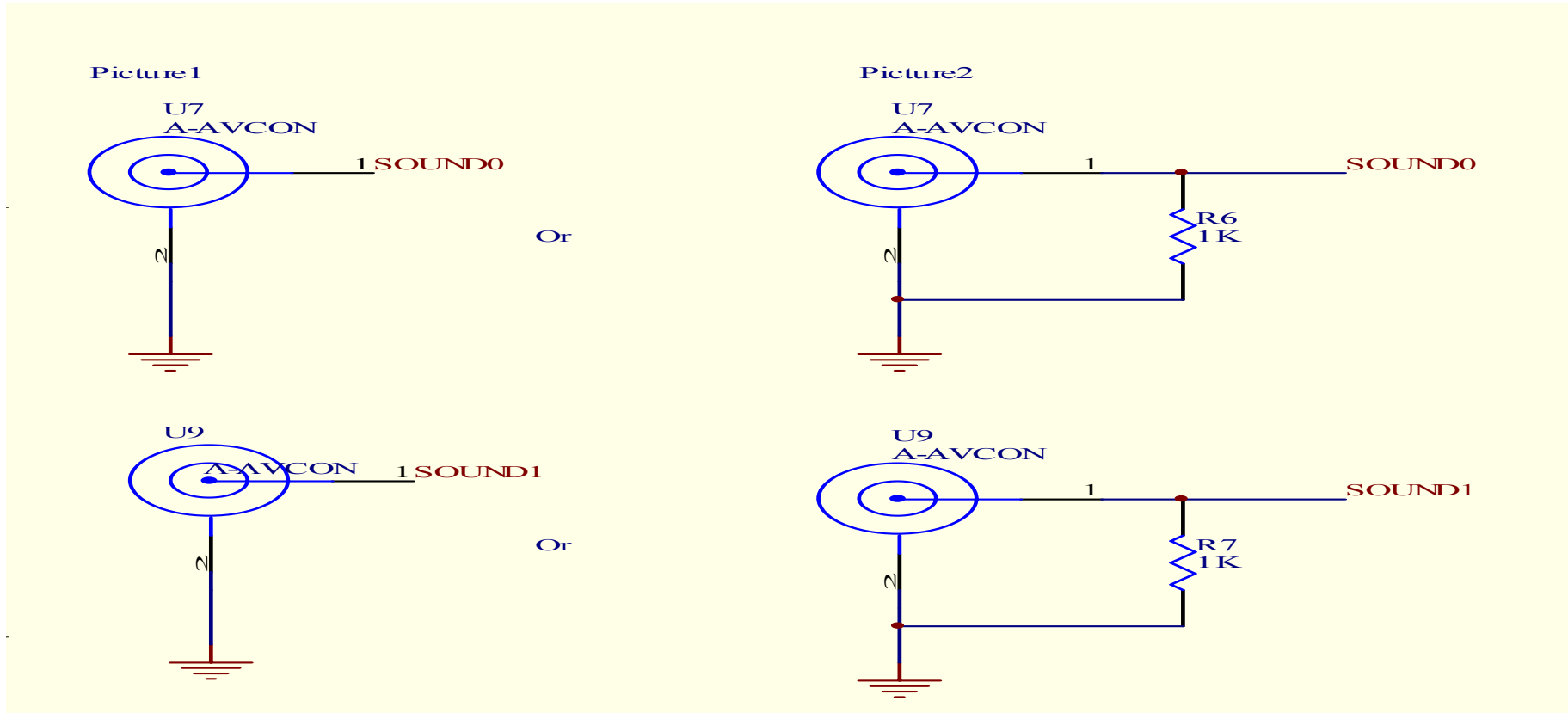

---- Directly receives the AV end from IC end Sound0, Sound1 the voice input contact (for example Picture 1), If wants to remove the television noise jamming to be possible to add 1Kohm(or above) resistor between IC Sound0, Sound1 and the ground (for example Picture2), but this resistor will make the volume of TV become small.

## **VT16 Application Note**

15>. Pin Optional (may adjust at will foot position)

---In the single bus operates, under 8 bits data bus mode has auxiliary 16 Input/Output pins, this 16 I/O ports are as a group altogether has 4 groups take 4 bit, in other words condition of the identical group must be completely same, cannot simultaneously have condition of Input and the Output in the identical group (IOP00~IOP03, IOP10~IOP13, IOP20~IOP23, IOP30~IOP33)

--- In the single bus operates, under 16 bits data bus mode has auxiliary 8 Input/Output pins, this 8 I/O ports are as a group altogether has 2 groups take 4 bit, in other words condition of the identical group must be completely same, cannot simultaneously have condition of Input and the Output in the identical group. (IOP20~IOP23, IOP30~IOP33)

---These I/O ports establishment please refers to the explanation of the data sheet.

--- As a result of these I/O port interior and non- Pull high resistance. If you must take these IO port when the High/Low control valve, please adds pull high resistor(~51Kohm) in front of the Vcc, otherwise it will cause of the system abnormal.